



Excavator SWE 25B

Greutate de operare	2.58t
Putere motor	15.5kW/2200rpm
Motor	YANMAR
Capacitate cupa	0.066m ³
Adancime de sapare	2.38m



Excavator SWE25B

Parametrii

MOTOR

Brand	YANMAR
Model	3TNV82A
Tip	3 cilindri, 4 timpi
Capacitate	1.33L
Putere	15.5kW/2200rpm

DIMENISUNI

Distanța contragreutate	546mm
Raza de inclinare a spatelui	1050mm
Lungime de transport	4220mm
Latime de transport	1400mm
Înălțime de transport	2400mm

SISTEM ELECTRIC

Voltaj nominal	12V
Baterii	63Ah
Alternator	12V-40A
Demaror	12V-1.7kW

INTERVALE DE LUCRU

Înălțime maximă de tăiere	4018mm
Înălțime maximă de încărcare	2812mm
Adâncime de lucru maximă	2375mm
Adâncime de sapare a peretelui vertical	1533mm
Lungime de sapare maximă	4463mm
Lungime de sapare la nivelul solului	4317mm
Forță de sapare a cupei	20.8kN
Forță de sapare piconului	13kN
Presiunea la sol	36kPa
Viteză de rotație	9rpm

CONDITII DE MERS

Max. Viteză Deplasare	4.1/2.7km/h
Greadibilitate	30°
Max. Traction	19kN

SASIU

Latime	1400mm
Latime senile	250mm
Lungime până la centrul rolor	1430mm
Lungime senile	1856mm
Înălțime senile	473mm

CAPACITATE

Rezervor combustibil	42.5L
Rezervor ulei hidraulic	30L

LAMA BULDOZERULUI

Independent moving, controlled by the gear shift	
Lungime X Latime	1400X324mm
Înălțime maximă de ridicare	270mm
Adâncime maximă de tăiere	310mm

SISTEM HIDRAULIC

Pompa principală	
Tip	2 pompe cu capacitate variabilă pompa cu o singură viteză
Capacitate	L/min
Presiune	24.5/20.5MPa

Excavator SWE 25B

Working Ranges

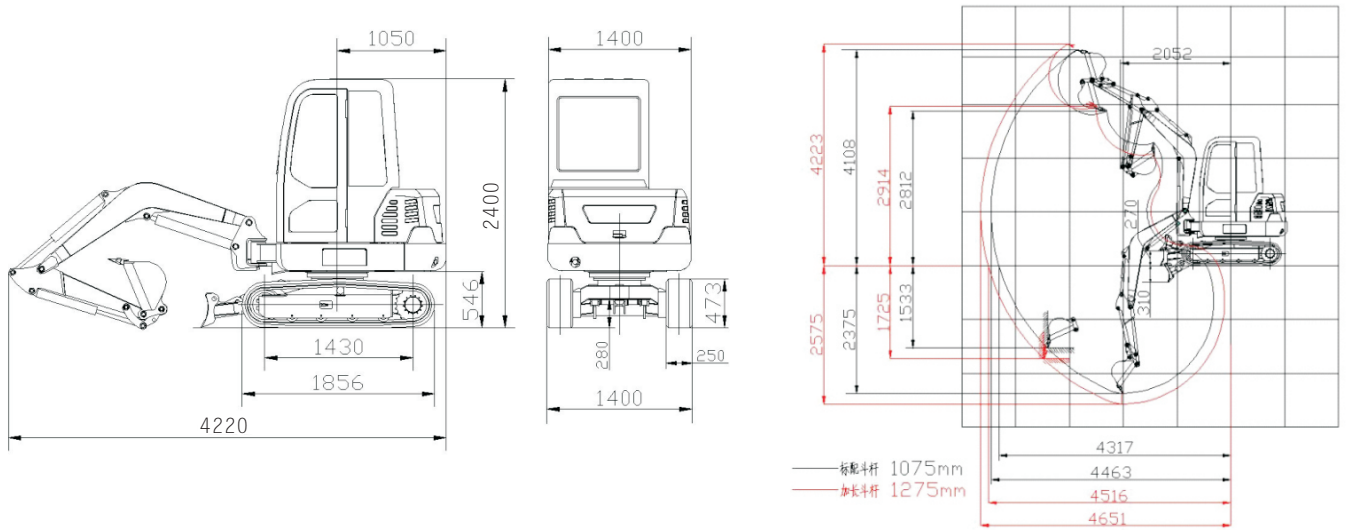

Load Capacity

B(m) \ A(m)	MAX		3.5m		3.0m		2.5m		2.0m	
	Front(kg)	Side(kg)	Front(kg)	Side(kg)	Front(kg)	Side(kg)	Front(kg)	Side(kg)	Front(kg)	Side(kg)
3.0	469.00*	404.30	—	—	469.00*	404.30	—	—	—	—
2.5	497.70*	350.70	—	—	512.10*	424.90	—	—	—	—
2.0	536.00*	313.50	550.40*	445.60	536.00*	424.90	670.00*	515.70	—	—
1.5	540.80*	288.80	564.70*	440.10	612.60*	420.80	813.60*	528.10	—	—
1.0	555.10*	280.50	583.90*	429.10	703.50*	396.10	875.80*	503.30	—	—
0.5	574.30*	276.40	617.40*	407.10	703.50*	371.30	961.90*	470.30	—	—
0.0	612.60*	276.40	650.90*	396.10	813.60*	358.90	947.60*	449.70	1292.20*	598.20
-0.5	650.90*	309.40	—	—	756.10*	367.20	861.40*	474.40	1196.40*	577.60
-1.0	679.60*	363.10	—	—	679.60*	375.40	823.10*	466.20	1005.00*	573.50

Notes:

- 1)Incarcaturile cu * sunt limitate de capacitatea hidraulica si bazate pe ISO 10567. Sarcinile nominale nu depasesc 87% din capacitatea hidraulica.
- 2)Incarcaturile fara* sunt limitate de sarcina de basculare si sunt bazate pe ISO 10567. Sarcinile nominale nu depasesc 75% din sarcina maxima de basculare.

SUNWARD INTELLIGENT EQUIPMENT CO.,LTD

Add: Sunward Intelligent Industrial Park, Xingsha, Changsha, 410100, China

Tel: 0086-731 8357 2828

Fax: 0086-731-8357 2661

Web: <http://www.sunward.com.cn>

E-mail: international@sunward.com.cn; info@sunward.cc

PC: 410100

